



中显液晶
技术资料



中显控制器使用说明书

2009年3月15日

北京市海淀区中关村大街32号和盛大厦811室
电话：(86)-010-52926620 传真：(86)-010-52926621
企业网站：<http://www.zxlcd.com>

KS0108B

64CH SEGMENT DRIVER FOR DOT MATRIX LCD

INTRODUCTION

The KS0108B is a LCD driver LSI with 64 channel output for dot matrix liquid crystal graphic display system. This device consists of the display RAM, 64 bit data latch 64 bit drivers and decoder logics. It has the internal display RAM for storing the display data transferred from a 8 bit micro controller and generates the dot matrix liquid crystal driving signals corresponding to stored data. The KS0108B composed of the liquid crystal display system in combination with the KS0107B (64 common driver)

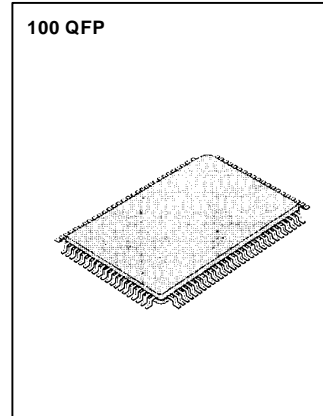

FEATURES

- Dot matrix LCD segment driver with 64 channel output
- Input and Output signal
 - Input: 8 bit parallel display data
 - Control signal from MPU
 - Splitted bias voltage (V1R, V1L, V2R, V2L, V3R, V3L, V4R, V4L)
 - Output: 64 channel waveform for LCD driving.
- Display data is stored in display data RAM from MPU.
- Interface RAM
 - Capacity: 512 bytes (4096 bits)
 - RAM bit data: RAM bit data = 1:ON
RAM bit data = 0:OFF
- Applicable LCD duty: 1/32~1/64
- LCD driving voltage: 8V~17V($V_{DD}-V_{EE}$)
- Power supply voltage: + 5V±10%

Driver		Controller
COMMON	SEGMENT	
KS0107B	Other KS0108B	MPU

- High voltage CMOS process.
- 100QFP and bare chip available.



KS0108B

64CH SEGMENT DRIVER FOR DOT MATRIX LCD

BLOCK DIAGRAM

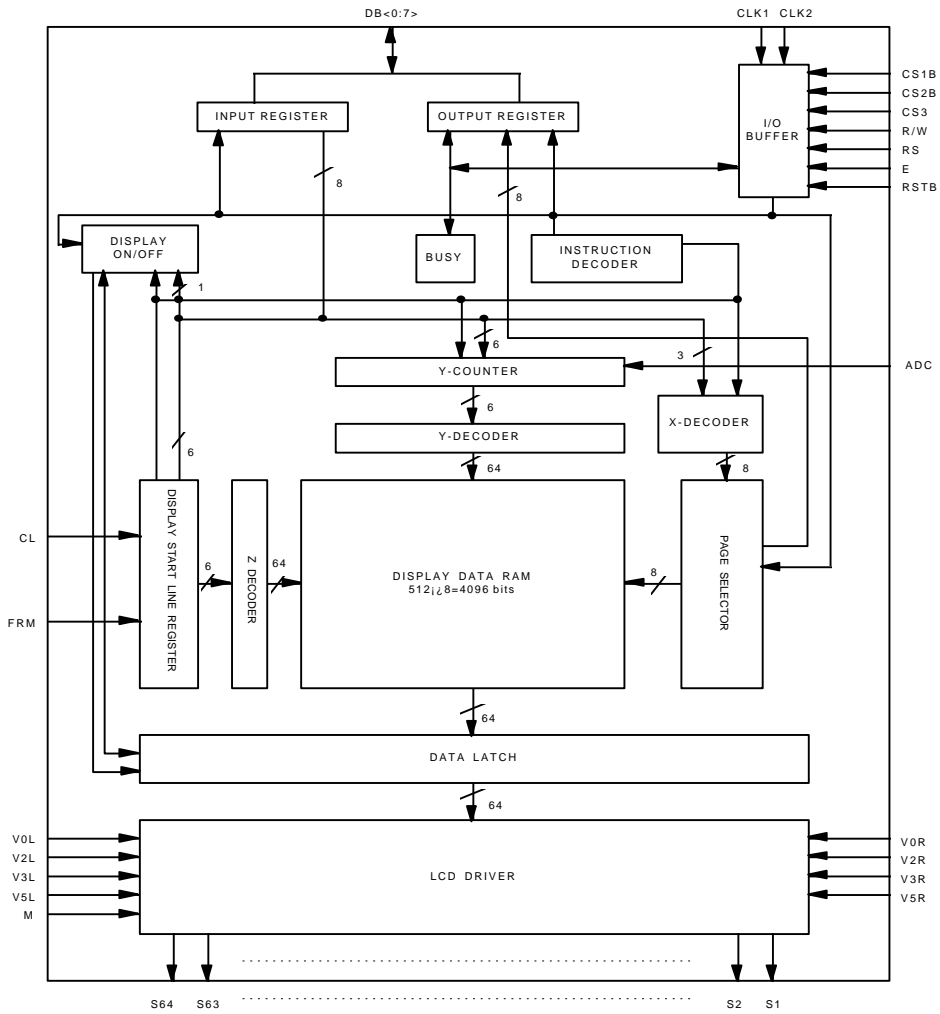

KS0108B

64CH SEGMENT DRIVER FOR DOT MATRIX LCD

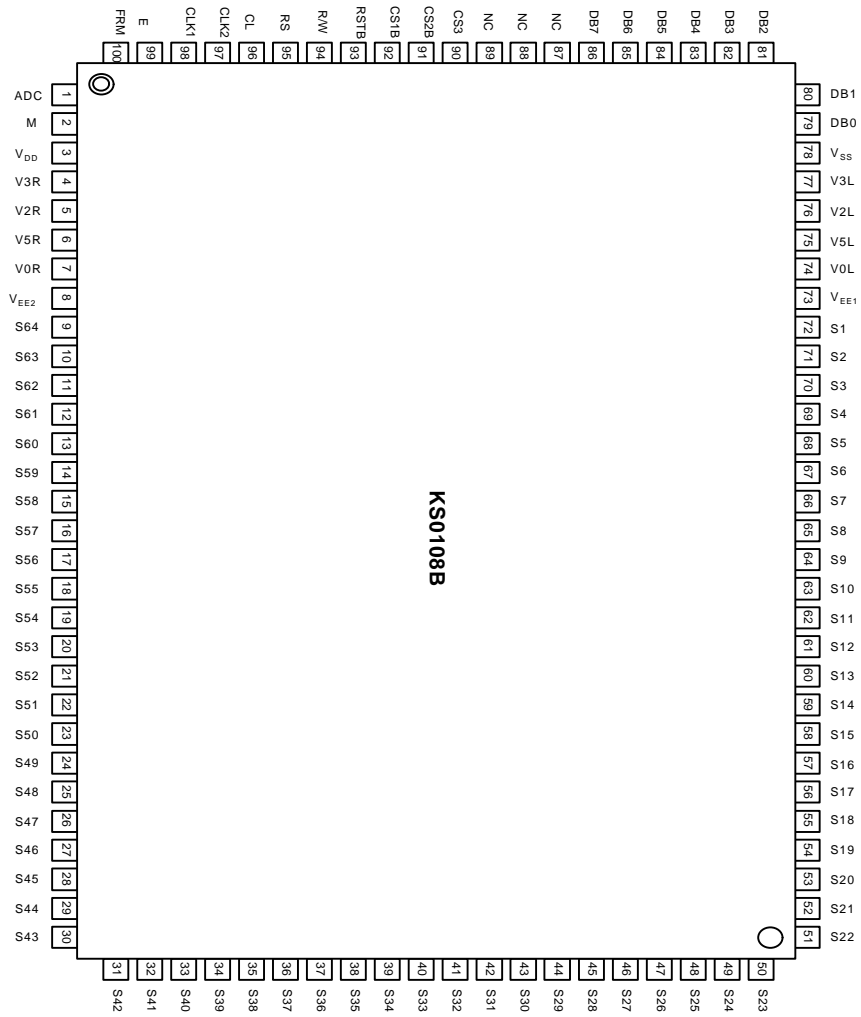

Fig.2. 100QFP Top View

PIN DESCRIPTION

PIN (NO)	SYMBOL	INPUT/OUTPUT	DESCRIPTION				
3 78 73, 8	V _{DD} V _{SS} V _{EE1,2}	Power	For internal logic circuit (+5V±10%) GND (0V) For LCD driver circuit V _{SS} =0V, V _{DD} =5V;±10% V _{DD} -V _{EE} =8V~17V V _{EE1} and V _{EE2} is connected by the same voltage.				
74, 7 76, 5 77, 4 75, 6	V0L, V0R V2L, V2R V3L, V3R V5L, V5R	Power	Bias supply voltage terminals to drive the LCD. <table border="1" style="margin-left: auto; margin-right: auto;"> <tr> <td>Select Level</td> <td>Non-Select Level</td> </tr> <tr> <td>V0L(R), V5L(R)</td> <td>V2L(R), V3L(R)</td> </tr> </table>	Select Level	Non-Select Level	V0L(R), V5L(R)	V2L(R), V3L(R)
Select Level	Non-Select Level						
V0L(R), V5L(R)	V2L(R), V3L(R)						
92 91 90	CS1B CS2B CS3	Input	Chip selection In order to interface data for input or output The terminals have to be CS1B=L, CS2B=L, and CS3=H.				
2	M	Input	Alternating signal input for LCD driving.				
1	ADC	Input	Address control signal of Y address counter. ADC=H→DB<0:7>=0→Y0→S1 DB<0:7>=63→Y63→S64 ADC=L→DB<0:7>=0→Y63→S64 DB<0:7>=63→Y0→S1				
100	FRM	Input	Synchronous control signal. Presets the 6-bit Z counter and synchronizes the common signal with the frame signal when the frame signal becomes high.				
99	E	Input	Enable signal. write mode (R/W=L) → data of DB<0:7> is latched at the falling edge of E. read mode (R/W=H) → DB<0:7> appears the reading data while E is at high level.				
98 97	CLK1 CLK2	Input	2 phase clock signal for internal operation. Used to execute operations for input/output of display RAM data and others.				
96	CL	Input	Display synchronous signal. Display data is latched at rising time of the CL signal and increments the Z-address counter at the CL falling time.				
95	RS	Input	Data or Instruction. RS=H→DB<0:7> : Display RAM Data RS=L→DB<0:7> : Instruction Data				
94	R/W	Input	Read or Write. R/W=H → Data appears at DB<0:7> and can be read by the CPU while E=H, CS1B=L, CS2B=L and CS3=H. R/W=L; Display data DB<0:7> can be written at falling of E when CS1B=L, CS2B=L and CS3=H.				
79~86	DB0~DB7	Input/Output	Data bus. These state I/O common terminal.				

KS0108B

64CH SEGMENT DRIVER FOR DOT MATRIX LCD

PIN DESCRIPTION(continued)

PIN (NO)	NAME	INPUT/OUTPUT	DESCRIPTION													
72~9	S1~S64	Output	LCD Segment driver output. Display RAM data 1:ON Display RAM data 0:OFF (Relation of display RAM data & M) <table border="1" style="margin-left: 20px;"> <thead> <tr> <th>M</th> <th>DATA</th> <th>Output Level</th> </tr> </thead> <tbody> <tr> <td rowspan="2">L</td> <td>L</td> <td>V₂</td> </tr> <tr> <td>H</td> <td>V₀</td> </tr> <tr> <td rowspan="2">H</td> <td>L</td> <td>V₃</td> </tr> <tr> <td>H</td> <td>V₅</td> </tr> </tbody> </table>	M	DATA	Output Level	L	L	V ₂	H	V ₀	H	L	V ₃	H	V ₅
M	DATA	Output Level														
L	L	V ₂														
	H	V ₀														
H	L	V ₃														
	H	V ₅														
93	RSTB	Input	Reset signal. When RSTB=L, (1) ON/OFF register becomes set by 0. (display off) (2) Display start line register becomes set by 0 (Z-address 0 set, display from line 0) After releasing reset, this condition can be changed only by instruction.													
87~89	NC		No connection.(open)													

MAXIMUM ABSOLUTE LIMIT

Characteristic	Symbol	Value	Unit	Note
Operating Voltage	V _{DD}	-0.3~+7.0	V	*1
Supply Voltage	V _{EE}	V _{DD} -19.0~V _{DD} +0.3	V	*4
Driver Supply Voltage	V _B	-0.3~V _{DD} +0.3	V	*1,3
	V _{LCD}	V _{EE} -0.3~V _{DD} +0.3	V	*2
Operating Temperature	T _{OPR}	-30~+85	°C	
Storage Temperature	T _{STG}	-55~+125	°C	

*1. Based on V_{SS}=0V.

*2. Applies the same supply voltage to V_{EE1} and V_{EE2}. V_{LCD}=V_{DD}-V_{EE}.

*3. Applies to M, FRM, CL, RSTB, ADC, CLK1, CLK2, CS1B, CS2B, CS3, E, R/W, RS and DB0~DB7.

*4. Applies V0L(R), V2L(R), V3L(R) and V5L(R).

Voltage level: V_{DD}≥V0L=VOR≥V2L=V2R≥V3L=V3R≥V5L=V5R≥V_{EE}.



KS0108B

64CH SEGMENT DRIVER FOR DOT MATRIX LCD

ELECTRICAL CHARACTERISTICS

DC Characteristics (V_{DD}=4.5~5.5V, V_{SS}=0V, V_{DD}-V_{EE}=8~17V, T_a=-30~+85°C)

Characteristic	Symbol	Condition	Min	Typ	Max	Unit	Note
Input High Voltage	V _{IH1}	-	0.7V _{DD}	-	V _{DD}	V	*1
	V _{IH2}	-	2.0	-	V _{DD}	V	*2
Input Low Voltage	V _{IL1}	-	0	-	0.3V _{DD}	V	*1
	V _{IL2}	-	0	-	0.8	V	*2
Output High Voltage	V _{OH}	I _{OH} =-200μA	2.4	-	-	V	*3
Output Low Voltage	V _{OL}	I _{OL} =1.6mA	-	-	0.4	V	*3
Input Leakage Current	I _{LKG}	V _{IN} =V _{SS} ~V _{DD}	-1.0	-	1.0	μA	*4
Three-state(OFF) Input Current	I _{TSL}	V _{IN} =V _{SS} ~V _{DD}	-5.0	-	5.0	μA	*5
Driver Input Leakage Current	I _{DIL}	V _{IN} =V _{EE} ~V _{DD}	-2.0	-	2.0	μA	*6
Operating Current	I _{DD1}	During Display	-	-	100	μA	*7
	I _{DD2}	During Access Access Cycle=1MHz	-	-	500	μA	*7
On Resistance	R _{ON}	V _{DD} -V _{EE} =15V I _{LOAD} =0.1mA	-	-	7.5	KΩ	*8

- *1. CL, FRM, M, RSTB, CLK1, CLK2
- 2. CS1B, CS2B, CS3, E, R/W, RS, DB0-DB7
- 3. DB0-DB7
- 4. Excepted DB0-DB7
- 5. DB0-DB7 at High Impedance
- 6. V0L(R), V2L(R), V3L(R), V5L(R)
- 7. 1/64 duty, FCLK=250KHZ, Frame Frequency=70HZ, Output: No Load
- 8. V_{DD}-V_{EE}=15.5V
V0L(R)>V2L(R)=V_{DD}-2/7 (V_{DD}-V_{EE})>V3L(R)=V_{EE}+2/7(V_{DD}-V_{EE})>V5L(R)

AC Characteristics (V_{DD}=5V±10%, V_{SS}=0V, T_a=-30°C~+85°C)

(1) Clock Timing

Characteristic	Symbol	Min	Typ	Max	Unit
CLK1, CLK2 Cycle Time	t _{CY}	2.5	-	20	μS
CLK1 'LOW' Level Width	t _{WL1}	625	-	-	ns
CLK2 'LOW' Level Width	t _{WL2}	625	-	-	
CLK1 'HIGH' Level Width	t _{WH1}	1875	-	-	
CLK2 'HIGH' Level Width	t _{WH2}	1875	-	-	
CLK1-CLK2 Phase Difference	t _{D12}	625	-	-	
CLK2-CLK1 Phase Difference	t _{D21}	625	-	-	
CLK1, CLK2 Rise Time	t _R	-	-	150	
CLK1, CLK2 Fall Time	t _F	-	-	150	



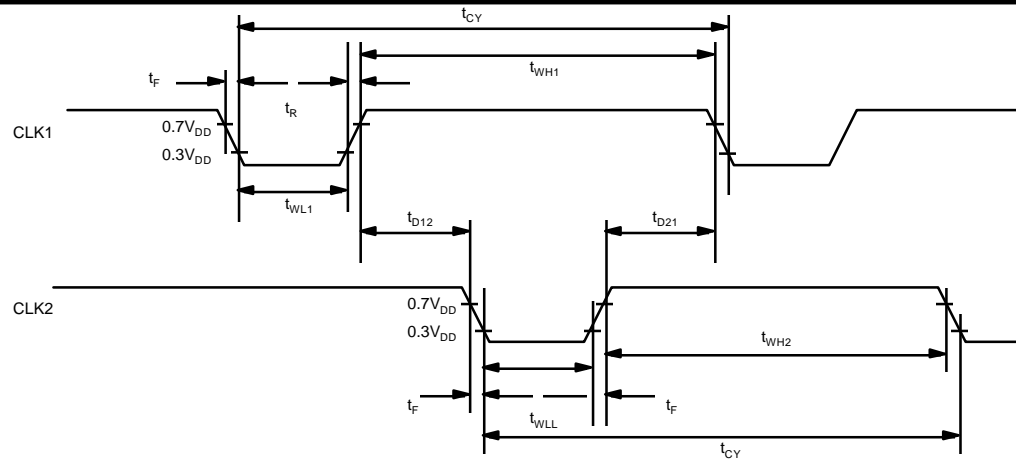

Fig 1. External clock waveform

(2) Display Control Timing

Characteristic	Symbol	Min	Typ	Max	Unit
FRM Delay Time	t_{DF}	-2	-	+2	us
M Delay Time	t_{DM}	-2	-	+2	us
CL 'LOW' Level Width	t_{WL}	35	-	-	us
CL 'HIGH' Level Width	t_{WH}	35	-	-	us

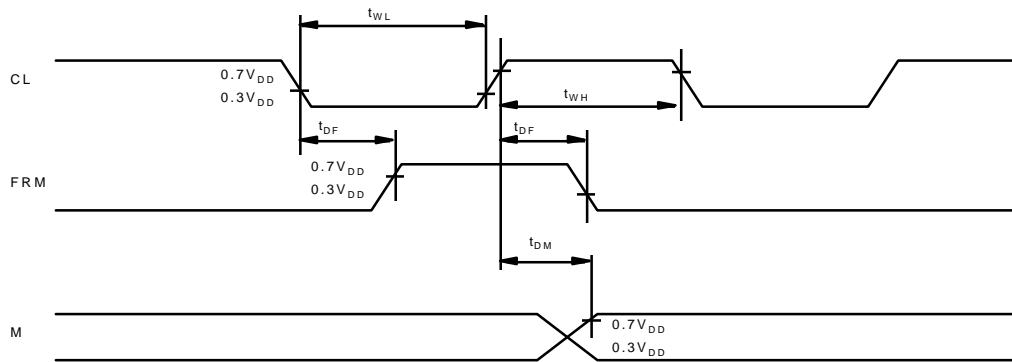

Fig 2. Display control signal waveform

(3) MPU Interface

Chatacteristic	Symbol	Min	Typ	Max	Unit
E Cycle	t_c	1000	-	-	ns
E High Level Width	t_{WH}	450	-	-	ns
E Low Level Width	t_{WL}	450	-	-	ns
E Rise Time	t_R	-	-	25	ns
E Fall Time	t_F	-	-	25	ns
Address Set-Up Time	t_{ASU}	140	-	-	ns
Address Hold Time	t_{AH}	10	-	-	ns
Data Set-Up Time	t_{DSU}	200	-	-	ns
Data Delay Time	t_D	-	-	320	ns
Data Hold Time (Write)	t_{DHW}	10	-	-	ns
Data Hold Time (Read)	t_{DHR}	20	-	-	ns

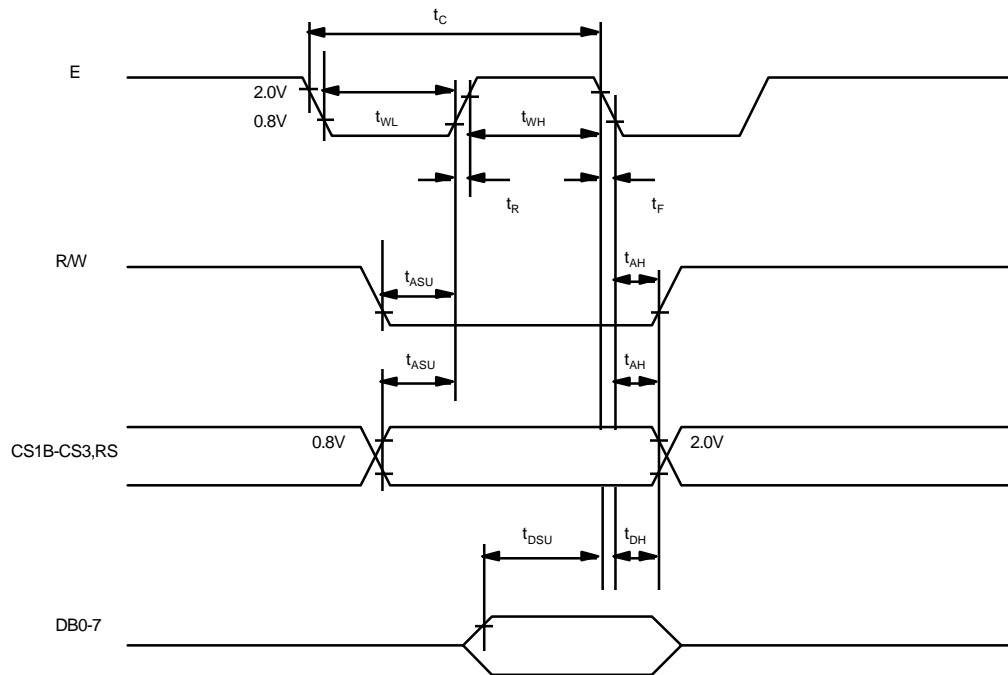

Fig 3. MPU write timing

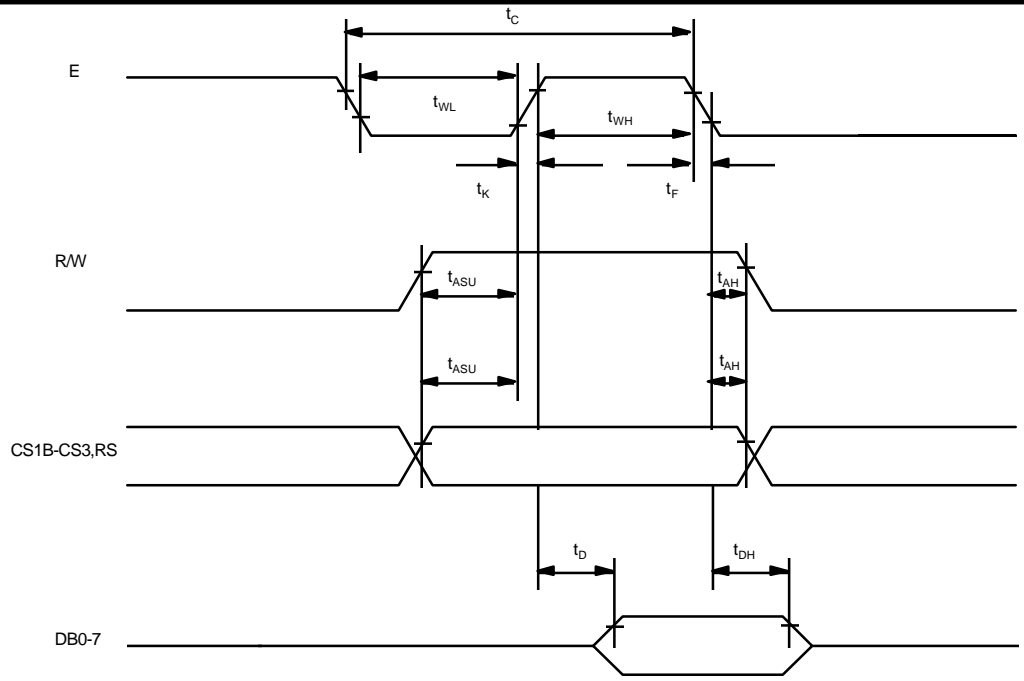

Fig 3. MPU write timing

KS0108B

64CH SEGMENT DRIVER FOR DOT MATRIX LCD

APPLICATION CIRCUIT

1.1/64 duty common driver(KS0107B) interface circuit

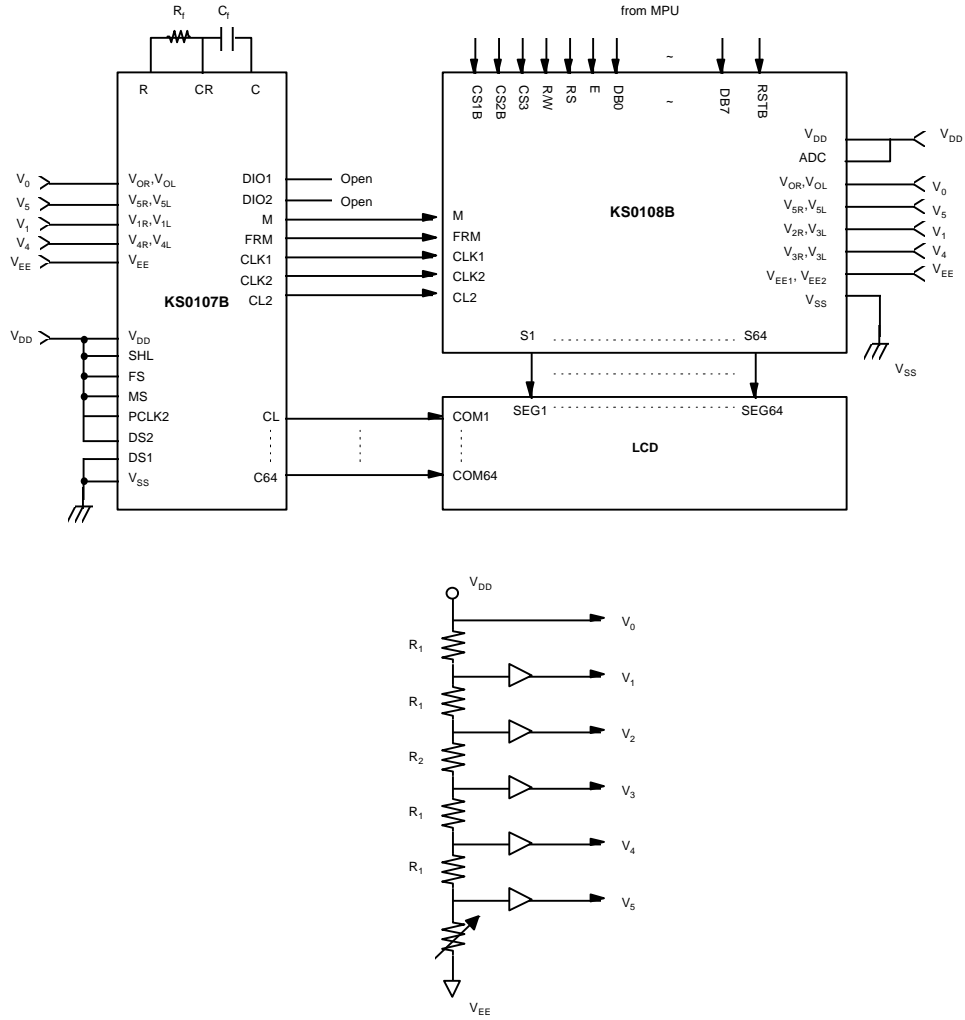

OPERATING PRINCIPLES & METHODS

1. I/O Buffer

Input buffer controls the status between the enable and disable of chip. Unless the CS1B to CS3 is in active mode, Input or output of data and instruction does not execute. Therefore internal state is not change. But RSTB and ADC can operate regardless CS1B-CS3.

2. Input register

Input register is provided to interface with MPU which is different operating frequency. Input register stores the data temporarily before writing it into display RAM.

When CS1B to CS3 are in the active mode, R/W and RS select the input register. The data from MPU is written into input register. Then Writing it into display RAM. Data latched for falling of the E signal and write automatically into the display data RAM by internal operation.

3. Output register

Output register stores the data temporarily from display data RAM when CS1B, CS2B, CS3 is in active mode and R/W and RS=H, stored data in display data RAM is latched in output register. When CS1B to CS3 is in active mode and R/W=H, RS=L, status data (busy check) can read out.

To read the contents of display data RAM, twice access of read instruction is needed. In first access, data in display data RAM is latched into output register. In second access, MPU can read data which is latched. That is, to read the data in display data RAM, it needs dummy read. But status read is not needed dummy read.

RS	R/W	Function
L	L	Instruction
	H	Status read (busy check)
H	L	Data write (from input register to display data RAM)
	H	Data read (from display data RAM to output register)

4. Reset

Reset can be initialized system by setting RSTB terminal at low level when turning power on, receiving instruction from MPU. When RSTB becomes low, following procedure is occurred.

1. Display off
2. Display start line register become set by 0.(Z-address 0)

While RSTB is low, any instruction except status read can be accepted. Reset status appears at DB4. After DB4 is low, any instruction can be accepted.

The Conditions of power supply at initial power up are shown in table 1.

Table 1. Power Supply Initial Conditions

Item	Symbol	Min	Typ	Max	Unit
Reset Time	t_{RS}	1.0	-	-	us
Rise Time	t_R	-	-	200	ns

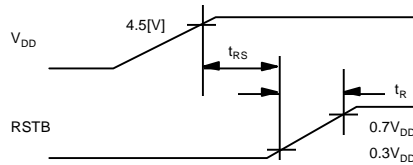

5. Busy flag

Busy flag indicates that KS0108B is operating or no operating. When busy flag is high, KS0108B is in internal operating. When busy flag is low, KS0108B can accept the data or instruction.
DB7 indicates busy flag of the KS0108B.

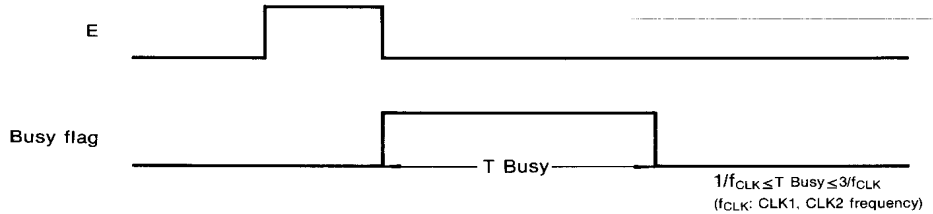
**6. Disp**

The display on/off flip-flop makes on/off the liquid crystal display. When flip-flop is reset (logical low), selective voltage or non selective voltage appears on segment output terminals. When flip-flop is set (logic high), non selective voltage appears on segment output terminals regardless of display RAM data.

The display on/off flip-flop can changes status by instruction. The display data at all segment disappear while RSTB is low.

The status of the flip-flop is output to DB5 by status read instruction.

The display on/off flip-flop synchronized by CL signal.

7. X Page Register

X page register designates page of the internal display data RAM.

It has not count function. An address is set by instruction.

8. Y address counter

Y address counter designates address of the internal display data RAM. An address is set by instruction and is increased by 1 automatically by read or write operations of display data.

9. Display Data RAM

Display data RAM stores a display data for liquid crystal display. To express on state dot matrix of liquid crystal display, write data 1. The other way, off state writes 0.

Display data RAM address and segment output can be controlled by ADC signal.

ADC=H₀; DB<0:7>=0 - Y-address 0 - A0 - S1

DB<0:7>=63 - Y-address 63 - A63 - S64

ADC=L₀; DB<0:7>=0 ~ Y-address 63 - A63 - S64

DB<0:7>=63 ~ A0 - S1

ADC terminal connect the V_{DD} or V_{SS}.

10. Display Start Line Register

The display start line register indicates of display data RAM to display top line of liquid crystal display.

Bit data (DB<0:5>) of the display start line set instruction is latched in display start line register. Latched data is transferred to the Z address counter while FRM is high, presetting the Z address counter.

It is used for scrolling of the liquid crystal display screen.

DISPLAY CONTROL INSTRUCTION

The display control instructions control the internal state of the KS0108B. Instruction is received from MPU to KS0108B for the display control. The following table shows various instructions.

Instruction	RS	R/W	DB7	DB6	DB5	DB4	DB3	DB2	DB1	DB0	Function
Display ON/OFF	L	L	L	L	H	H	H	H	H	L/H	Controls the display on or off. Internal status and display RAM data is not affected. L:OFF, H:ON
Set Address	L	L	L	H	Y address (0~63)					Settings the Y address in the Y address counter.	
Set Page (X address)	L	L	H	L	H	H	H	Page (0~7)			Sets the X address at the X address register.
Display Start Line	L	L	H	H	Display start line (0~63)					Indicates the display data RAM displayed at the top of the screen.	
Status Read	L	H	B U S Y	L	O N / O F F	R E S E T	L	L	L	L	Read status. BUSY L: Ready H: In operation ON/OFF L: Display ON H: Display OFF RESET L: Normal H: Reset
Write Display Data	H	L	Write Data								Writes data (DB0:7) into display data RAM. After writing instruction, Y address is increased by 1 automatically.
Read Display Data	H	H	Read Data								Reads data (DB0:7) from display data RAM to the data bus.

2. Timing diagram (1/64 duty)

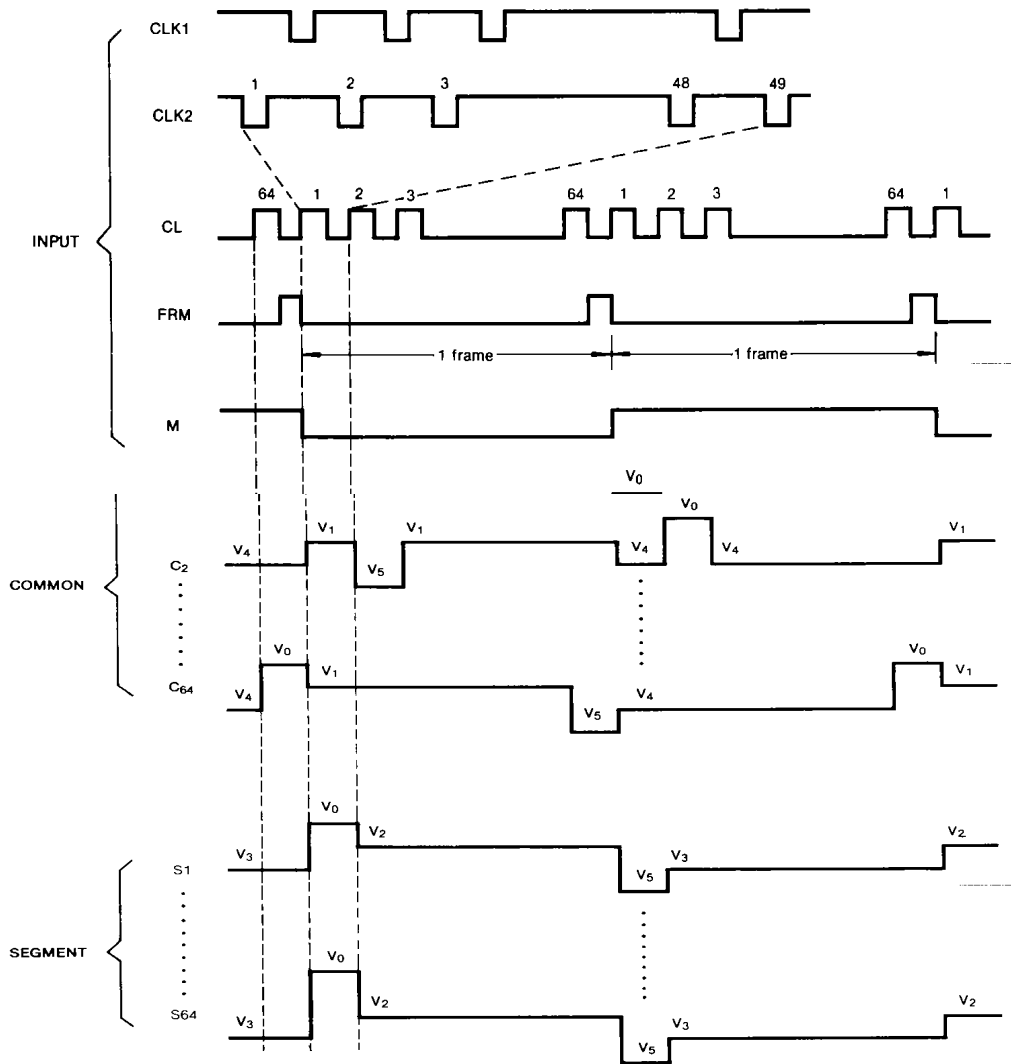

ELECTRONICS

3. LCD Panel interface application circuit

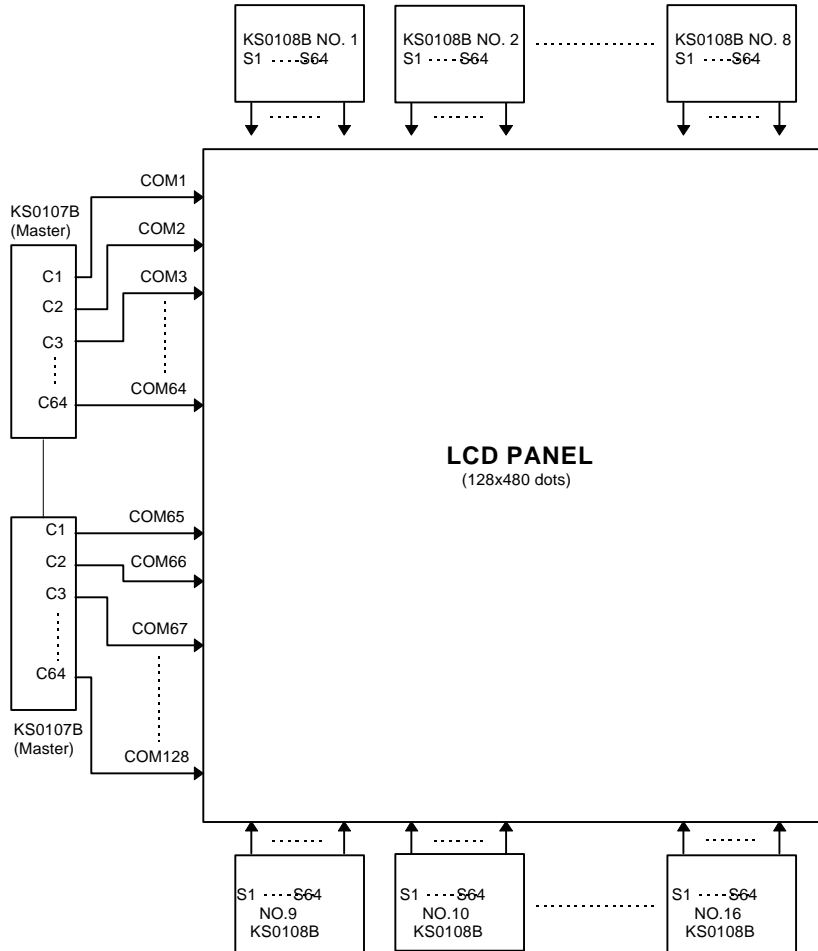

KS0108B

64CH SEGMENT DRIVER FOR DOT MATRIX LCD

PAD DIAGRAM

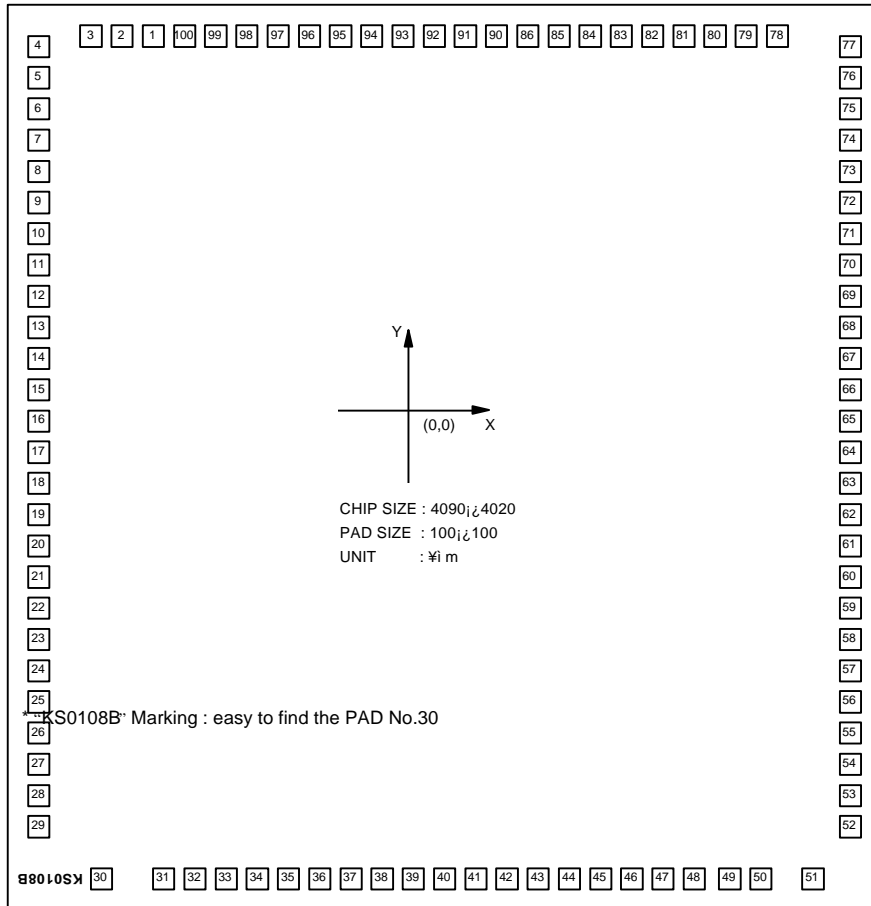

PAD LOCATION

PAD NUMBER	PAD NAME	COORDINATE		PAD NUMBER	PAD NAME	COORDINATE		PAD NUMBER	PAD NAME	COORDINATE	
		X	Y			X	Y			X	Y
1	ADC	-1140	1845	35	S38	-687	-1845	69	S4	1882	791
2	M	-1275	1845	36	S37	-562	-1845	70	S3	1882	916
3	VDD	-1410	1845	37	S36	-437	-1845	71	S2	1882	1041
4	V3R	-1882	1809	38	S35	-312	-1845	72	S1	1882	1166
5	V2R	-1882	1684	39	S34	-187	-1845	73	VEE1	1882	1310
6	V5R	-1882	1559	40	S33	62	-1845	74	V0L	1882	1435
7	V0R	-1882	1434	41	S32	62	-1845	75	V5L	1882	1559
8	VEE2	-1882	1309	42	S31	187	-1845	76	V2L	1882	1684
9	S64	-1882	1165	43	S30	312	-1845	77	V3L	1882	1809
10	S63	-1882	1040	44	S29	437	-1845	78	VSS	1412	1845
11	S62	-1882	915	45	S28	562	-1845	79	DB0	1277	1845
12	S61	-1882	790	46	S27	687	-1845	80	DB1	1142	1845
13	S60	-1882	665	47	S26	812	-1845	81	DB2	1007	1845
14	S59	-1882	540	48	S25	937	-1845	82	DB3	882	1845
15	S58	-1882	415	49	S24	1062	-1845	83	DB4	757	1845
16	S57	-1882	290	50	S23	1187	-1845	84	DB5	632	1845
17	S56	-1882	165	51	S22	1487	-1845	85	DB6	507	1845
18	S55	-1882	40	52	S21	1882	-1379	86	DB7	382	1845
19	S54	-1882	-84	53	S20	1882	-1239	87		NC	
20	S53	-1882	-209	54	S19	1882	-1099	88		NC	
21	S52	-1882	-334	55	S18	1882	-959	89		NC	
22	S51	-1882	-459	56	S17	1882	-834	90	CS3	245	1845
23	S50	-1882	-584	57	S16	1882	-709	91	CS2B	120	1845
24	S49	-1882	-709	58	S15	1882	-584	92	CSTB	-5	1845
25	S48	-1882	-834	59	S14	1882	-459	93	RSTB	-130	1845
26	S47	-1882	-959	60	S13	1882	-334	94	RAW	-255	1845
27	S46	-1882	-1099	61	S12	1882	-209	95	RS	-380	1845
28	S45	-1882	-1239	62	S11	1882	-84	96	CL	-505	1845
29	S44	-1882	-1379	63	S10	1882	41	97	CLK2	-630	1845
30	S43	-1487	-1845	64	S9	1882	166	98	CLK1	-755	1845
31	S42	-1187	-1845	65	S8	1882	291	99	E	-880	1845
32	S41	-1062	-1845	66	S7	1882	416	100	FRM	-1005	1845
33	S40	-937	-1845	67	S6	1882	541				
34	S39	-812	-1845	68	S5	1882	666				